



Use and Maintenance Manual

ATS LOGICA CONTROL PANEL Model with ATS115

Filename: Use and Maintenance
Manual
Rev. 01 Date: 01/03/2016
Product: ATS LOGICA Control Panel
Model with ATS115

THIS MANUAL IS TO BE CONSIDERED AN ATTACHMENT OF THE ATS115 CONTROLLER.

INDEX

1. Introduction to the manual (see also ATS115 manual)	3
2. General conditions of use (see also ATS115 manual)	4
3. Installation Instructions (see also ATS115 manual)	5
3.1 Safety distances	6
3.2 Control Panel protection	6
4. Start-up	7
4.1 Operating logic (<i>standard version</i>).....	7
4.2 Operating DC voltage modification (HW).....	8
4.3 Operating AC voltage modification (HW) (<i>see also attached document</i>).....	8
4.4 Operating AC voltage modification and SW operation (<i>see also attached document</i>)	12
4.5 Operating Logic (<i>standard version</i>)	16
4.5.1 Switch carried out by interlocked contactors.....	16
4.5.2 Switch carried out by motorized changeover switch	17
4.5.3 Power cables interconnections and how to tighten the screws	20
4.5.4 AUTO Operating mode	22
4.5.5 MANUAL Operating mode	23
4.5.6 Position 0 (OFF)	23
5. Composition of the Panel	24
5.1 Connection interface terminal board (Switch and Auxiliaries).....	28
6. Options available and possible configurations of the controller	31
6.1 Battery Charger SW 5A 12Vdc or 24Vdc (<i>see also related datasheet</i>)	31
6.2 Management of two Gensets switching	32
Option kit diodes bridge D1	32
Option kit relay KA	33
6.3 Communication ports: RS232, ETHERNET, RS485 (<i>only with ATS115Plus</i>)	33
6.4 Inhibition	33
6.5 CTs.....	34
7. Check and maintenance (see also ATS115 manual)	35
8. Transport, storage and decommissioning	36
9. Faults and possible causes (see also ATS115 manual)	37
10. How to ask for assistance	39
11. Our range: overall dimensions	40

1. Introduction to the manual (see also ATS115 manual)

SICES is pleased to thank you for purchasing our ATS LOGICA Automatic Transfer Switch Panel. This Control Panel is the result of the design, the selection of the best components, the careful assembly and the strict test to which all SICES products are submitted.

We would like to recommend to read this manual carefully, to observe the safety rules and all regulations for the correct use and maintenance of the ATS LOGICA Control Panel. This will guarantee you better duration results and efficiency.





For any doubts or questions, please do not hesitate to contact our technicians for clarifications.

The information contained in this manual are updated to the printing stage, but they may still be modified without notice in compliance with our aims of continuous development and improving of products.

This manual and all the enclosed documents are to be intended as part of the Control Panel and are intended to be read by all persons are involved in the life cycle of the machinery. Therefore they must be collected in a well-known place and be accessible to the operators, keeping them carefully in order to avoid their loss and/or deterioration.

This manual has been drafted for the installer, the user and the maintenance technician. It is compulsory to read it carefully and examine all electrical diagrams and instructions enclosed, as they provide indications on the Control Panel use and they also show the technical characteristics as well as the installation and assembling features.

The Customer must complies with all the safety instructions.

 	<p>WARNING: The automatic transfer switch control panel must be only used by properly trained personnel. The installation must only be planned and carried out by skilled personnel. Any fault in installation and use may cause serious damage to the machinery, to the user system and to the persons involved.</p>
	<p>Please note that it is compulsory to observe all regulations in force in the country of installation. In case of more regulations in force on the same matter, always consider the strictest ones.</p>
	<p>WARNING: 400V – 50 Hz.</p>

2. General conditions of use (see also ATS115 manual)

The product has been designed and manufactured in compliance with the safety regulations in force, for use in normal and not classified environments. In order to prevent damages/injuries to things and persons, we strictly recommend to use all necessary cautions and observe the regulations.

The control panel sizes for the calculation of the dissipated thermal power have been estimated considering that no other heating sources occur nearby. If the control panel is placed into a room together with other panels, a suitable distance must be guaranteed in order to allow the dissipation of the heating produced.

The calculation has been carried out for a use at an **average environmental temperature of 35°C**, according to the rules CEI EN 60439-1/2.



In case of need of use at a different environmental temperature, please contact our technical department for the proper evaluations.

The Control Panel is intended to be used only to the purpose for which it has been designed. Any other use is considered improper and therefore dangerous.

3. Installation Instructions (see also ATS115 manual)



Do not carry out or try to perform the start-up, maintenance, reparation or modification you have neither the competence nor the particular instructions. If any doubt persists after reading the following paragraphs and attachments, please do not hesitate to contact the SICES Technical Service. All operations must be always performed in compliance with the safety regulations.

We recommend to check that the Control Panel is intact after unpacking. In case of any doubts, do not use it, but refer to the manufacturer under penalty of nullity of the warranty.

Before proceeding to the installation, ensure you checked and observed the following indications:

- All installation operations must be performed by skilled personnel who strictly observe the safety regulations in force in the country where the installation takes place;
- Ensure that the data on the label identifying the control panel comply with the plant values; in detail, check power, voltage, current and frequency;
- For the electric connection strictly follow the enclosed electric diagram (**it contains useful information**);
- In the connection of power and command lines we recommend you to guarantee at least the section value suggested;
- Ensure that the connection of the earthing protection conductor is always connected compatibly with the distribution system and the regulations in force in the country of use;
- **Ensure that the conductors of the auxiliary circuit are correctly connected. Also check the correct connection of phase and neutral conductors.**



A wrong or missed neutral conductor connection may cause serious damages to the Control Panel and to the distribution plants connected to it.

Install the Control Panel according to the protection degree. We recommend you to use a cable gland with the same characteristics in order to avoid a decreasing of the protection value.

The Control Panels must be installed properly. Any faults, modifications to the original project or interference caused by external agents such as plants, animals, dust, mould, etc. must be removed or refreshed to the default values.

3.1 Safety distances

	<p>The panel must be placed at a safe distance from heating sources, fuel storage, flammable material (paper, cloth, etc.) and chemical substances. The precautions adopted must be those approved by the competent authorities. In order to avoid potentially dangerous situations, isolate the area around the panel preventing unauthorised personnel from approaching.</p> <p>Although SICES products comply with the electromagnetic compatibility rules, still we strongly recommend NOT to install the Panel (and the Genset) next to equipment ejecting emissions.</p>
---	--

Pay special attention while assembling the Control Panel in order to prevent external elements from falling into the Panel, such as metal shavings or other which could damage or impede the operation of the electric components.

<p>Note</p>	<p>It is the installer's responsibility to provide a DECLARATION OF CONFORMITY on the Control Panel installation once the work has been completed.</p>
--------------------	--

	<p>WARNING: A wrong installation or electrical connection may cause serious damage to people, Genset, ATS Control Panel and/or plant connected to it.</p>
--	--

3.2 Control Panel protection

In order to protect the panel from indirect contact, overload and short-circuit, it is the installer's responsibility to connect a protection device on Source A (MAINS) and B (GENSET) with the correct characteristics and values for the installation point.

In order to guarantee against electrodynamic stress caused by a short circuit for control panels fixed to the floor, it is necessary to fix the lines to each other or to a support. It is also necessary to provide supports for the power cables so that these do not weigh down the transfer switch connection bars. It is the installer's responsibility to check that the electrical loads connected to the load and the related current values do not exceed the panel projected value.

	<p>The installer must provide the installation of all the necessary equipment aimed at guarantee a safe and correct operation of the system in which the ATS LOGICA Control Panel and Genset are installed (e.g. coordination of the protections against direct and indirect contacts).</p>
---	---

Notes: We recommend you to use the suitable equipment (overvoltage protectors) in order to protect the circuits directly supplied by the Mains from overvoltage due to atmospheric discharges or particular events.

4. Start-up

4.1 Operating logic (*standard version*)



WARNING:

Every control panel is produced and configured for operations at: **400V – 50 Hz.**

- Control panels between 45 and 125A have the following voltage and frequency values:

DC voltage:

12Vdc.

AC voltage:

400Vac.

(The ABB contactors coils can work at 100÷250V.)

Frequency:

- 1) **50Hz.**
- 2) **60Hz.**

It is possible change the frequency values by modifying a parameter on the ATS115 controller (SW).

- Control panels between 160 and 4000A have the following voltage and frequency values:

DC voltage switch.

The Control Panels are suitable for operating at different genset battery voltages:

- 1) **12Vdc.**
- 2) **24Vdc.**

It is possible change this level by modifying the Hardware on the control panel internal wiring (see par. 4.2).

AC voltage switch.

The Control Panels are suitable for operating at different AC voltages:

- 3) **220Vac.**
- 4) **380Vac.**
- 5) **400Vac.**
- 6) **440Vac.**

In order to adjust the Control Panel to the different AC voltage level, it is necessary to carry out some operations related to both control panel internal connections (HW) and ATS115 controller parameters modifications (SW).

Frequency:

- 1) 50Hz.
- 2) 60Hz.

It is possible change the frequency values by modifying a parameter on the ATS115 controller (SW).

4.2 Operating DC voltage modification (HW)

In order to change the DC voltage, connect the 2.7B wire (identified by red rings) to the RB wire clamp:

- 1) Battery Voltage 12Vdc: wire 2.7B to wire clamp 12
- 2) Battery Voltage 24Vdc: wire 2.7B to wire clamp 24.



(Example of 24Vdc operation)

4.3 Operating AC voltage modification (HW) *(see also attached document)*

For the HW change, see the attached document in the documentation supplied with the control panel and reported below.



WARNING: All voltage switch operations have to be carried out before the operation start, with absence of voltage.

THE CONTROL PANEL IS PRODUCED AND CONFIGURED FOR THREE-PHASE + NEUTRAL 400V OPERATIONS.

WARNING:

The cables in the figures below have a numeration that may not correspond to the control panel in use.

They only have a demonstrative purpose. See the electrical diagram to identify the right cable number to take in consideration in order to modify the operating voltage.

The sticker on the control panel rear door identifies the internal equipment.

BEFORE CHANGING THE VOLTAGE:

Disconnect the supply of the following devices: “**KBG**” (capacity 160÷4000A), “**KR-KG**” (capacity 45÷125A), power supply “**A2**” (optional).

“KBG”

Remove the protection panel and disconnect the changeover switch connector.
 KBG = ABB (Lower side) KBG = TECHNOELECTRIC (Upper side)



“KR-KG”

Disconnect the coil supply connector.



“A2” (optional)

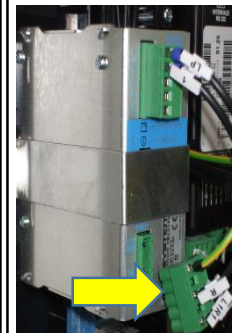

For the voltage change (size 45÷125A) please contact SICES Sales Department.

The **VOLTAGE SWITCH** is carried out in the “X1” bar and in the “TR1” autotransformer for 160÷4000A capacities.

X1



TR1

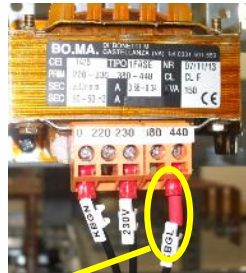

On “X1” bar and on “TR1” the connected cables are identified by **3 red rings**.

ENSURE THAT THE CABLES WITH THE RED RINGS ARE PLACED AS REPORTED IN THE ELECTRICAL DIAGRAM SPECIFICATIONS.

ENSURE THAT THE CABLES WITH THE RED RINGS ARE PLACED AS REPORTED BELOW AND SEE THE ELECTRICAL DIAGRAM SPECIFICATIONS FOR THE IDENTIFICATION OF THE NUMBER OF CABLES.

OPERATING VOLTAGE: 220V (MOVE THE RED RINGED CABLE ONLY)

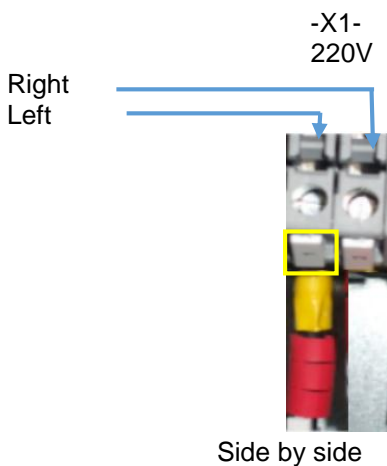

NOTE: for the side by side “X1” bar, the red ringed cable is connected to the terminals with an “**odd number**” (left).

WARNING: it is advisable to move one cable at a time in order to avoid inverting the sequence with the other cables.

CHECK THE VOLTAGE ON THE SWITCH AND POWER SUPPLY CONNECTORS (OPTIONAL).

After the control panel is configured with the correct voltage value, supply the “XR” and “XG” bar with the operating voltage in order to check.
 The voltage on the “XM-1” and “XM-2” bar and on the “KBG” switch supply connector (ABB), or with “KR” and “KG” must be **230V**.

Disconnect the voltage and put the supply connectors again at their place:

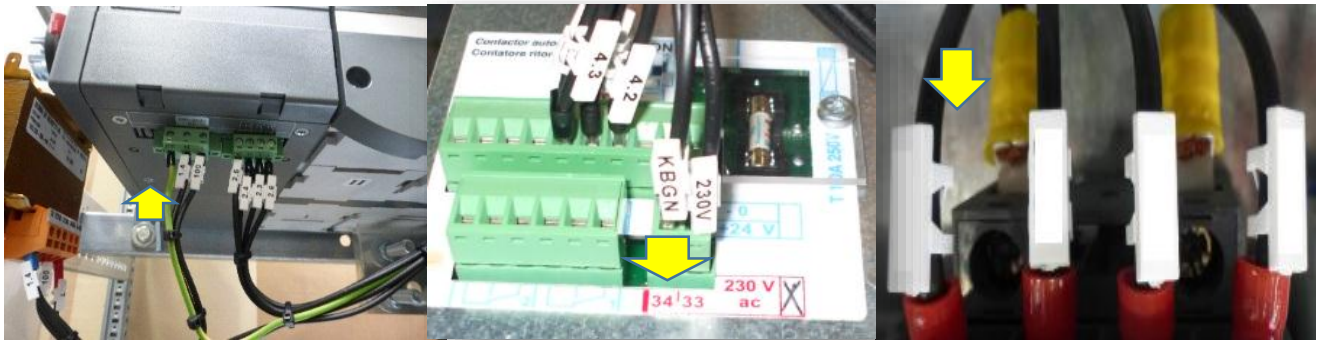

“KBG”
ABB

“KBG”
TECHNOELECTRIC

“KR-KG”

OPERATING VOLTAGE: 380/400/440V (move the red ringed cable only)

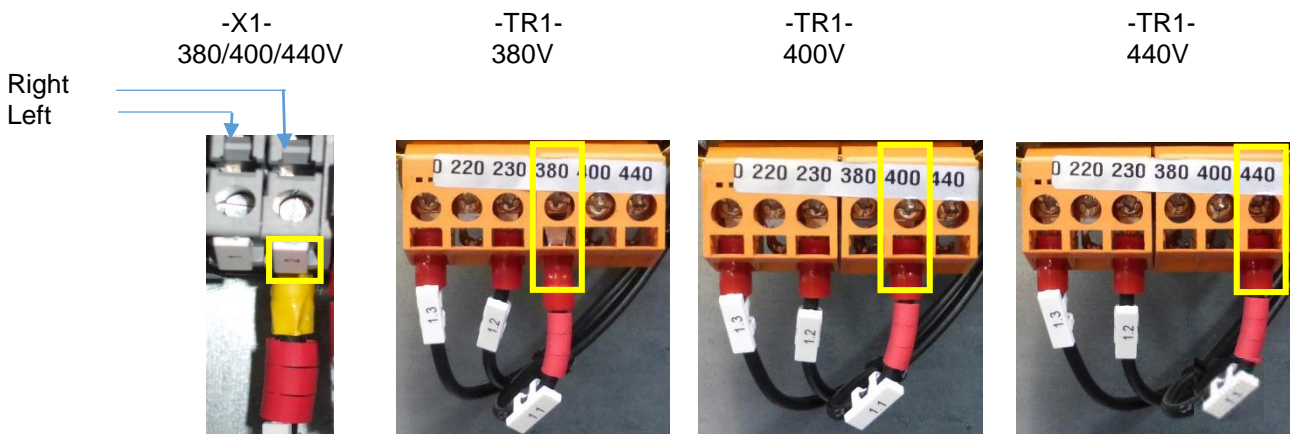

Side by side

NOTE: for the side by side “X1” bar, the red ringed cable is connected to the terminals with an “**even number**” (right).

WARNING: it is advisable to move one cable at a time in order to avoid inverting the sequence with the other cables.

4.4 Operating AC voltage modification and SW operation (see also attached document)

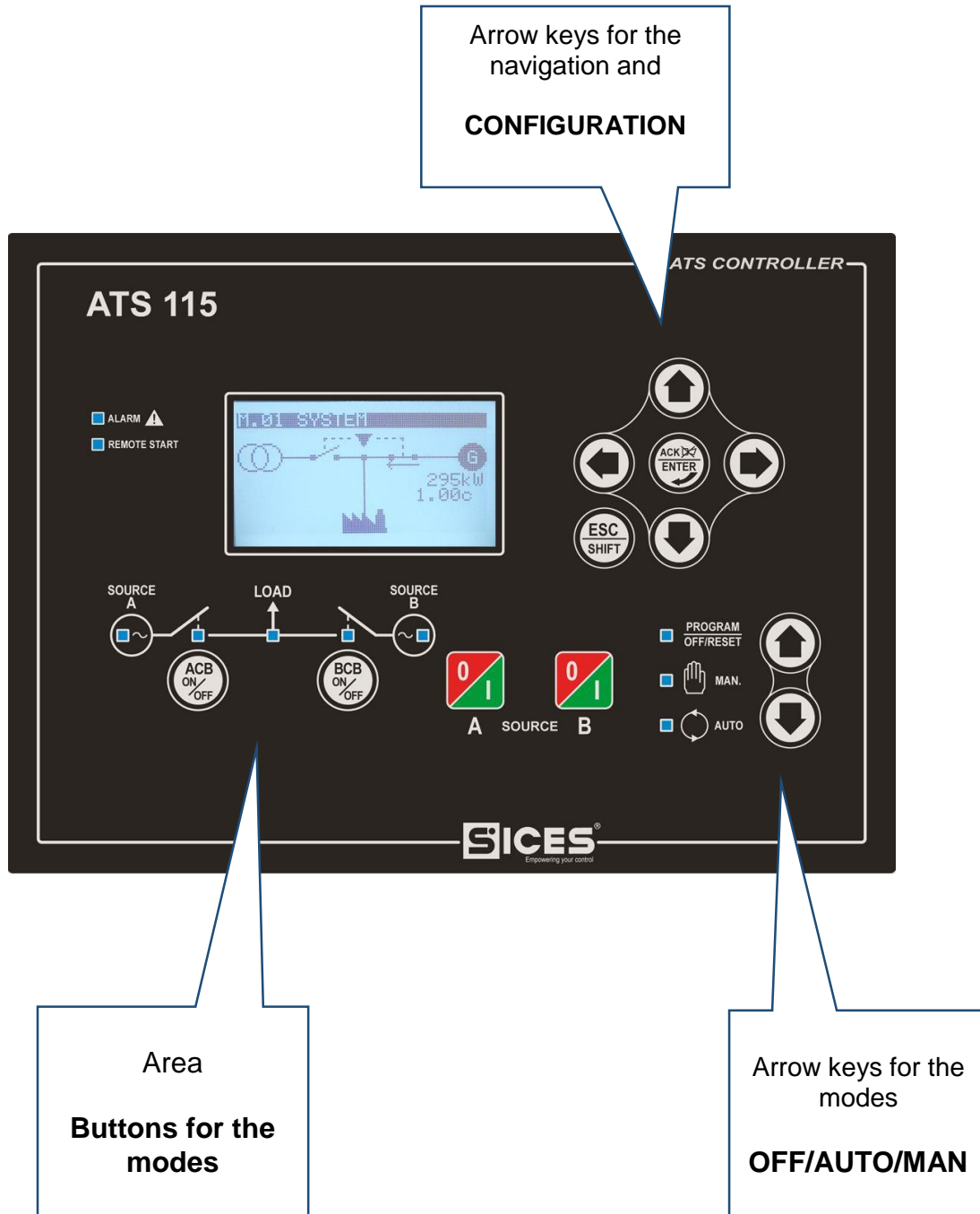

OFF / AUTO / MAN Set the parameters by means of the configuration keyboard.

OFF/AUTO/MAN Area

Using the arrow keys put the device on



CONFIGURATION Area

Using the arrow keys select the page 03 PROGRAM



+



Using the arrow keys select the submenu: 1 System



+



Using the arrow keys select the submenu: 1.2 - Source A (see the example)
1.3 - Source B



Using the arrow keys and scroll the parameters indicated (the example indicates the parameter P.0102)

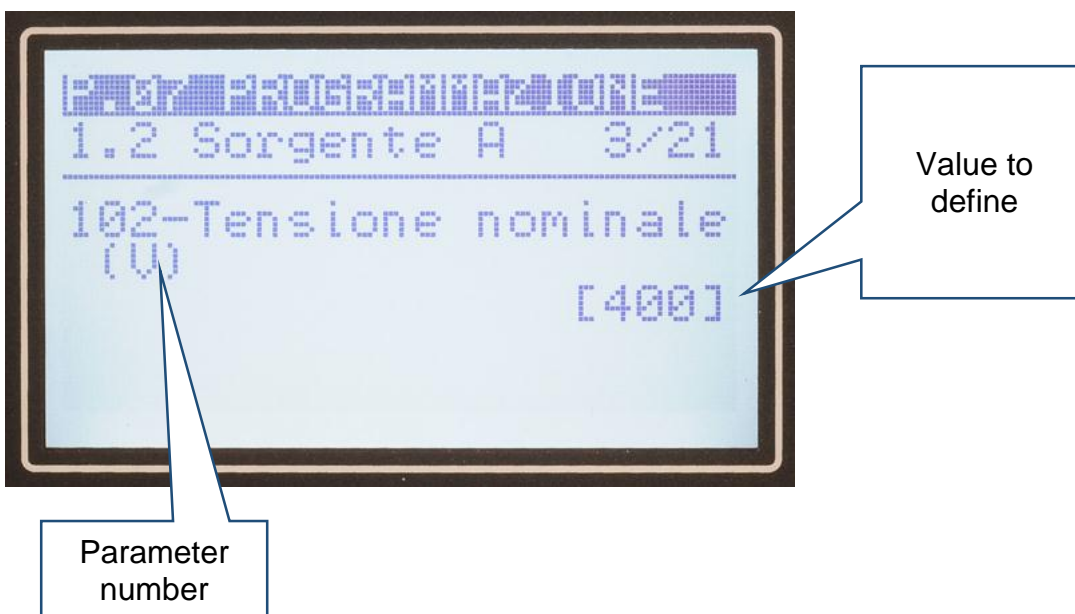

The square brackets [] flash to indicate that the value can be changed. Using the arrow keys define the new value and confirm with ENTER (the square brackets stop flashing).



Press ESC in order to go back to the main menu and to browse through pages. The parameters that must be changed for the voltage modification are all listed in the submenu 1-System.

Find below the new values to define (see the ATS115 manual in order to change the parameters by the controller keyboard).

- 1) Operating voltage 220V
 - a. P.0102 = 220
 - b. P.0202 = 220

- 2) Operating voltage 380V
 - a. P.0102 = 380
 - b. P.0202 = 380

- 3) Operating voltage 400V:
 - a. P.0102 = 400
 - b. P.0202 = 400

- 4) Operating voltage 440V:
 - a. P.0102 = 440
 - b. P.0202 = 440

- 5) Nominal frequency 50Hz:
 - a. P.0301 = 50

- 6) Nominal frequency 60Hz:
 - a. P.0301 = 60



4.5 Operating Logic (*standard version*)

The ATS LOGICA Control Panel is a device that allows to supply alternatively a system that uses two different and independent sources of energy, which usually are: Source A (Mains) and/or Source B (Genset).

According to the nominal current, besides the panel circuits, the switch takes place by means of:

- 1) 2 four-pole contactors which are electrically and mechanically interlocked (45 - 125A);
- 2) 1 motorized four-pole changeover switch (160 – 4000A).

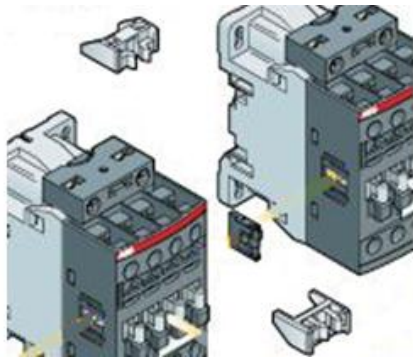
4.5.1 Switch carried out by interlocked contactors

Mechanical interlock		Auxiliary contacts
		
45÷125A		45÷125A

The contactors are interlocked by means of a proper accessory. In order to guarantee more safety to the system, besides the mechanical interlock, there is an electrical interlock carried out by auxiliary contacts installed on the front of each contactor.

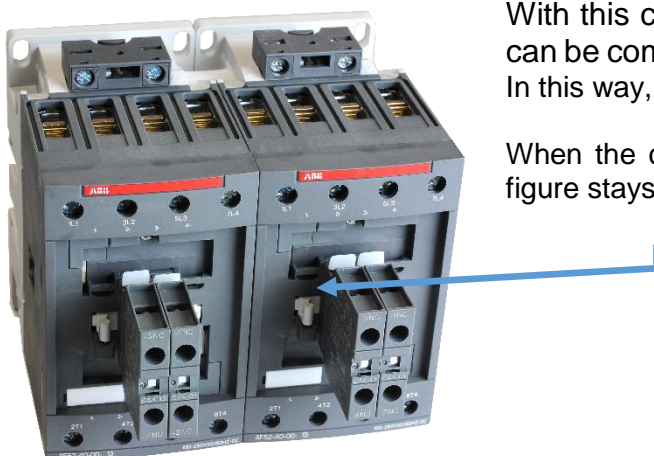

With this configuration, only one of the two contactors can be commanded; the second one stays deactivated. In this way, the load is always supplied by only one source.

When the contactor is closed, the mechanical part in the figure stays blocked.

4.5.2 Switch carried out by motorized changeover switch

The standard version considers the use of the following materials:

From 160A to 2500A: Motorized changeover switch ABB SACE

From 3150 to 4000A: Motorized changeover switch TECHNOELECTRIC

On the front of the motorized changeover switch (160÷4000A) there is a mechanical indicator that shows the status of the main contacts. Therefore, it is possible to understand on which source the load is inserted. The figure below shows the possible statuses:

ABB SACE

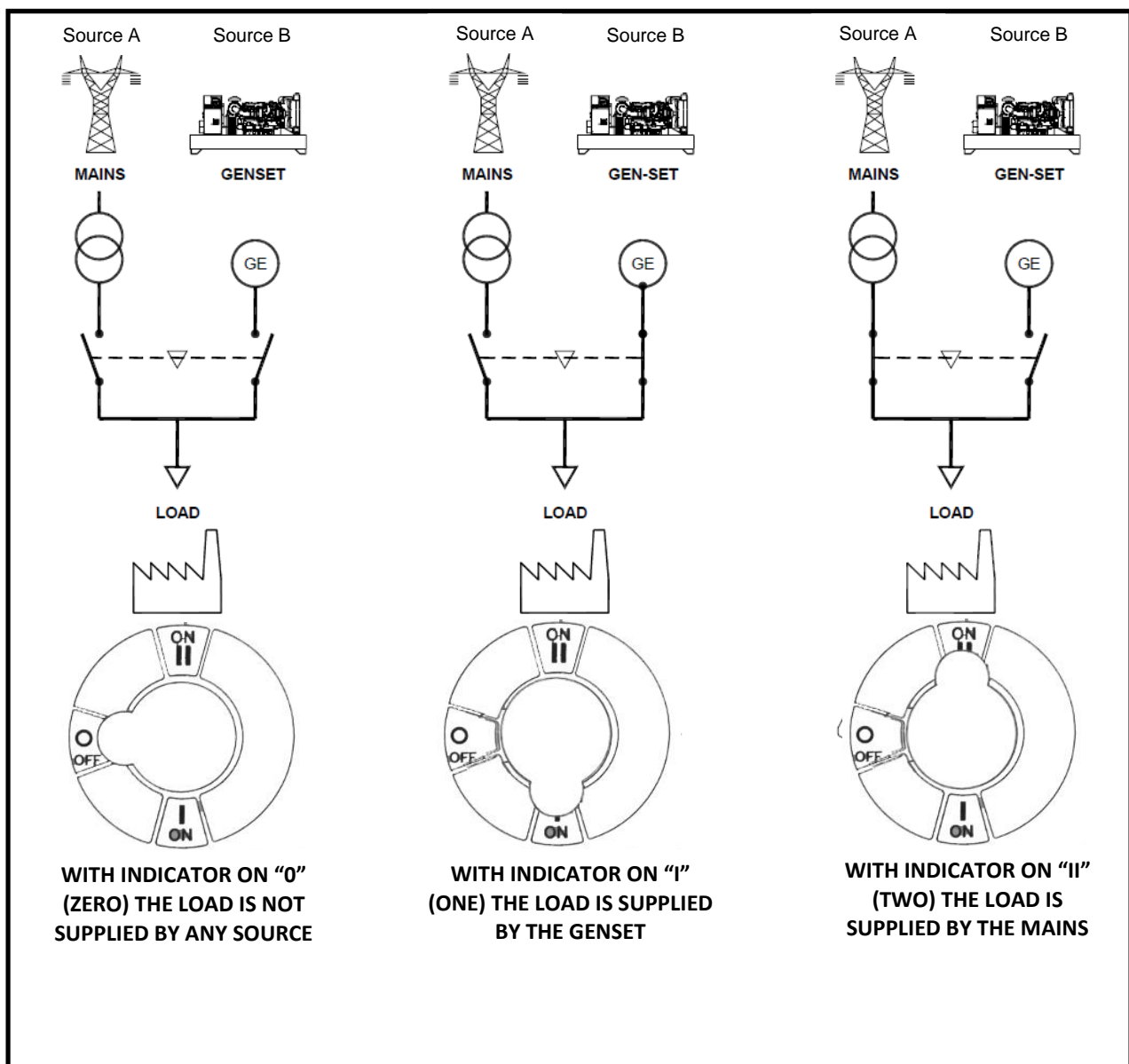

TECHNOELECTRIC

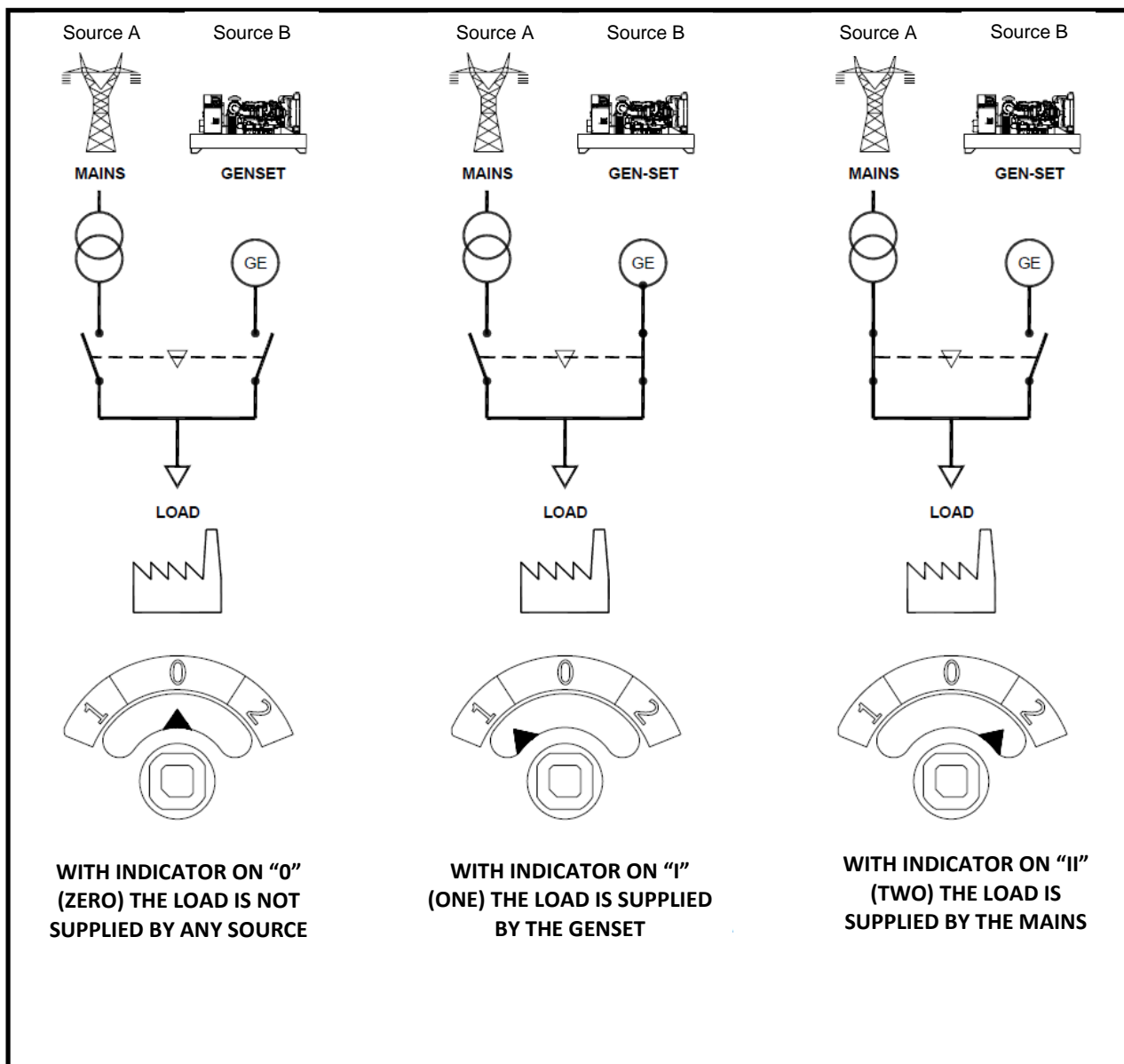

WARNING: Check the cyclic sense of the Source A (MAINS) and the Source B (GENSET) phases before supplying the LOAD.
The inverse cyclic sense can cause serious damages to the system.

On the front of the switch there is a series of accessories:

- 1 **A lock that impedes any manual or electrical operation.**
- 2 **Mechanical indicator of the circuit breakers status.**
- 3 **Command selector switch: manual/automatic.**

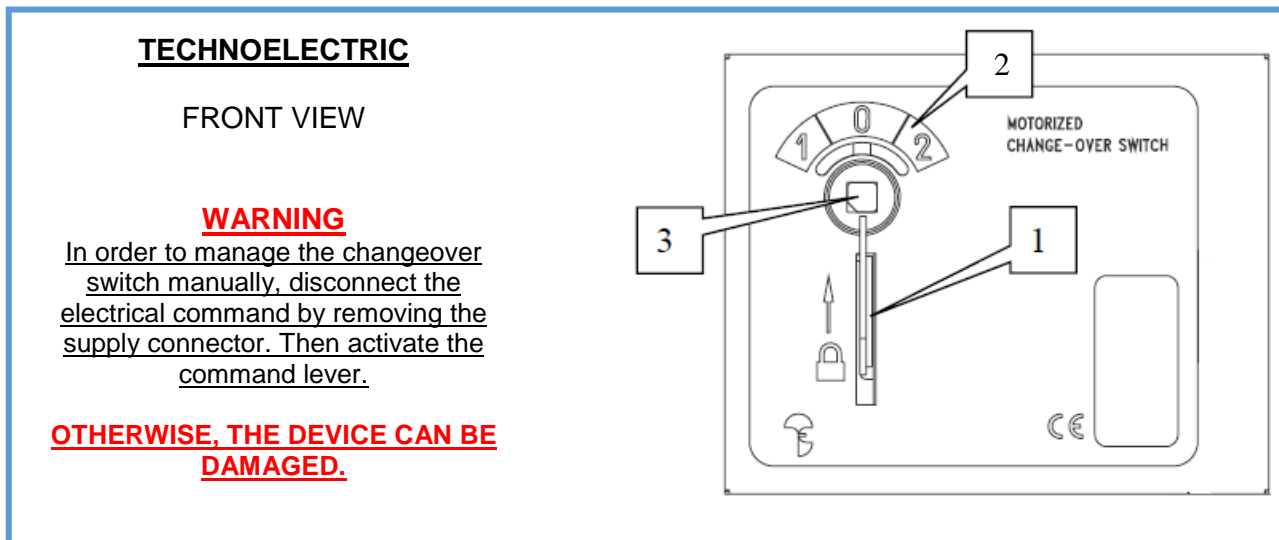
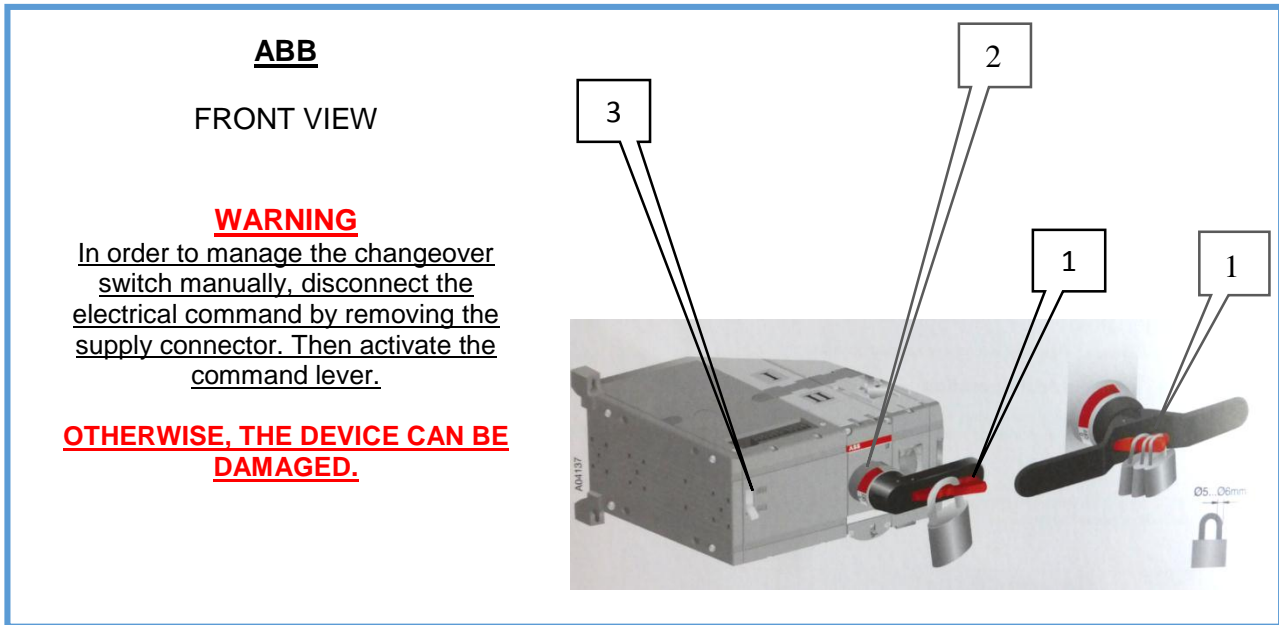

The locking device is important in case you would like to impede any operation by unauthorized persons, or to guarantee that nobody modifies the supply status creating damage to the people working in the plant. By means of the locking system placed on the front, you impede the activation of the manual command. With lock inserted the supply is stopped, inhibiting the electrical command.

The changeover switch, thanks to its exclusive mechanical structure, can be activated manually by a proper lever. This operation can be useful in case of device failure or in case of connection failure to the remote control logic.

In order to make the changeover switch close one of the two sources and supply the load, the ATS LOGICA control panel must be always connected to receive the values of the SOURCE A (MAINS) and SOURCE B (GENSET) voltage, keeping the ATS115 controller on AUTO.

4.5.3 Power cables interconnections and how to tighten the screws

When the connection of the power cables Source A (MAINS) - Source B (GENSET) is carried out directly on the contactors terminals (sizes 45÷125A), the operation brings to the disconnection of the auxiliary circuits cables connected to the terminals. Pay attention during the reconnection of the auxiliary circuits cables to the power cables in the terminals. Before supplying, ensure that they have been reconnected correctly according to the diagram.

A wrong connection can cause damage to the auxiliary circuits inside the electrical control panel.



For the other sizes (160-4000A), this procedure is not necessary as the power cables connection is carried out on the extension bars.

Pay attention during the closure of the screws that keep the connectors in the terminal boards, avoid over pressing, respect the values below:

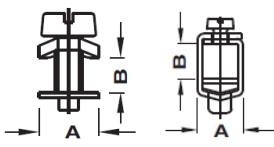
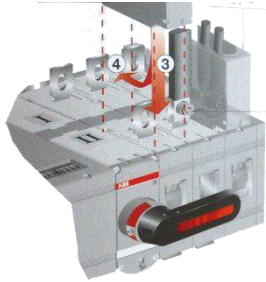
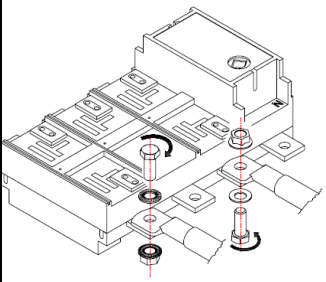
									
CLOSURE (MAX.)									
CONNECTOR (45-125A)			MOTORIZED CHANGEOVER SWITCH (160-2500A)					MOTORIZED CHANGEOVER SWITCH (3150-4000A)	
BF26	BF38	BF50/65 BF80	OTM160 OTM250	OTM400	OTM600 OTM800	OTM1000 OTM1600	OTM2000 OTM2500	CS6	
M4	M5	M6	M8	M10	M12	M12	M12	M14	
1 Nm	3.9 Nm	5 Nm	22 Nm	44 Nm	75 Nm	75 Nm	75 Nm	70 Nm	

	<p>WARNING: Before connecting phase and neutral cables of SOURCE A (MAINS), SOURCE B (GENSET) and LOAD to the ATS LOGICA panels, the installer is responsible of checking the type of distribution system of the plant. Pay attention while checking the neutral function. Remember <u>NOT TO SECTION IT</u> if the neutral and protection function has been selected (PEN).</p>
---	--

	<p>WARNING: A wrong or failed connection of the neutral conductor may cause serious damages to the panel and to the related distribution systems.</p>
---	--

4.5.4 AUTO Operating mode



The operation cycle is composed as follows:

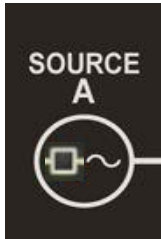

In case of SOURCE A (MAINS) failure or values out of tolerance (values and configurations are set by the ATS115 controller), and ATS115 on AUTOMATIC, the KB relay allows the activation of the SOURCE B (GENSET) (the contact N.O. closes on terminals XM-110 and 111).



After the Source B (Genset) is started, the voltage created is acknowledged by the ATS115 controller.

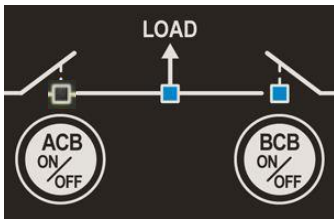

Then it commands the status switch from SOURCE A (MAINS) to SOURCE B (GENSET).

With SOURCE A (MAINS) within the tolerance thresholds,

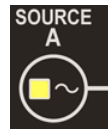

back,

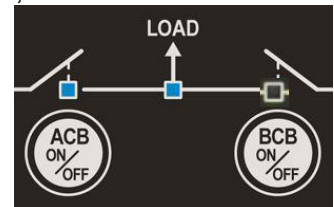

the ATS115 controller manages an inverse sequence with respect to the previous one, switching the supply on the Source A (Mains) and deactivating the Source B (Genset) by opening the KB starting contact

4.5.5 MANUAL Operating mode



Manual activation of SOURCE A /B.



Manual stop of SOURCE A/B



In MAN mode, with supply on SOURCE B (GENSET), press ACB to switch on SOURCE A (MAINS);



With supply on SOURCE A (MAINS), press BCB to switch on SOURCE B (GENSET). Make sure that the controller commanded the start of the Genset, and that the Genset is connected with right voltage.

4.5.6 Position 0 (OFF)

With supply on SOURCE B (GENSET), press **BCB** once, in order to switch the Load on 0; with supply on SOURCE A (MAINS), press **ACB** once in order to switch the Load on 0.

This operation cycle is managed with times and thresholds configured in the ATS115 controller: all these values can be adjusted by the user by consulting the proper device manual.

NOTE: with SOURCE A (MAINS) live and with ATS115 on OFF, the motorized changeover switch is commanded to close on SOURCE A (MAINS).

5. Composition of the Panel

CARPENTRY (45÷125A)

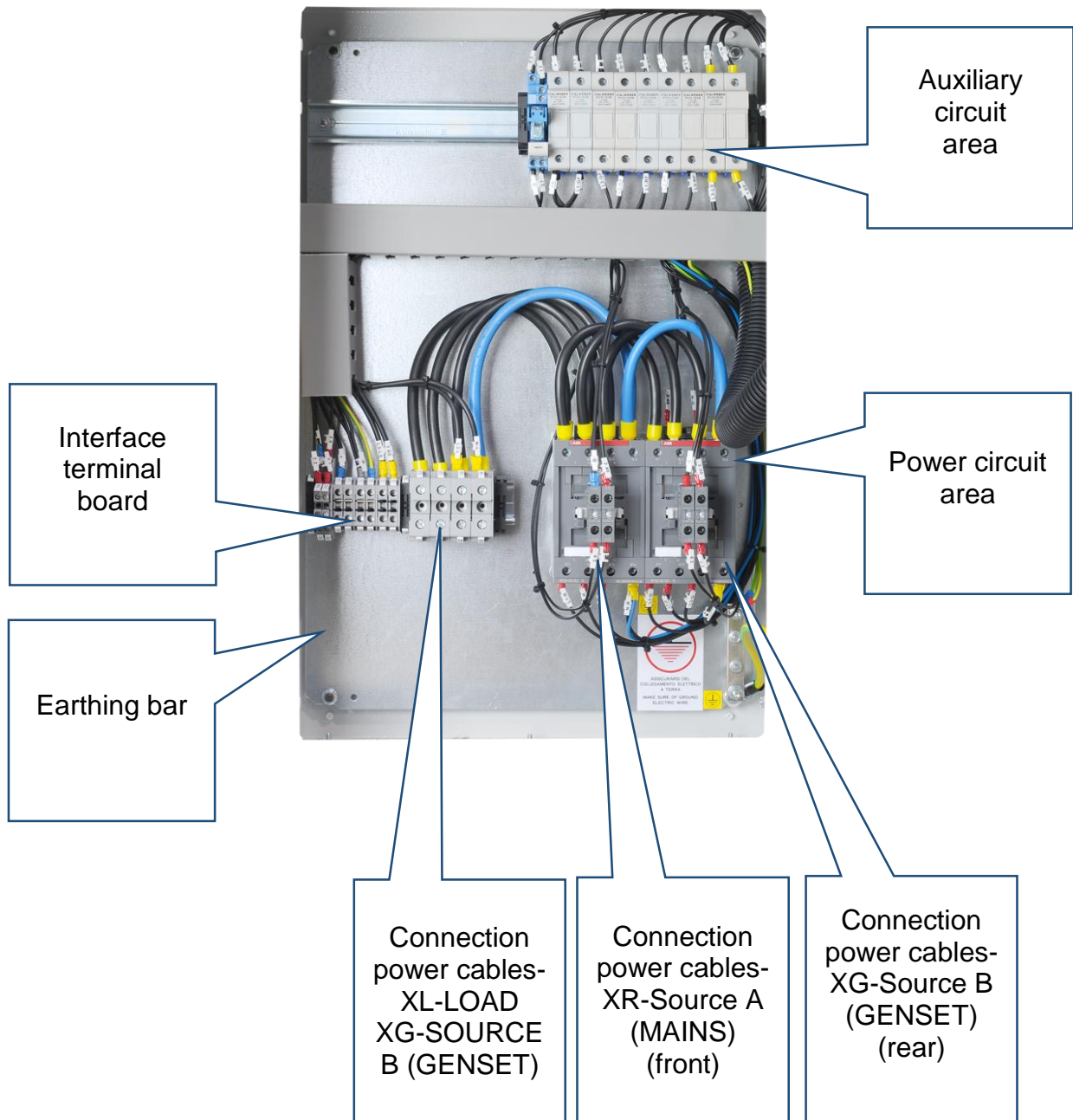

CARPENTRY (160÷800A)

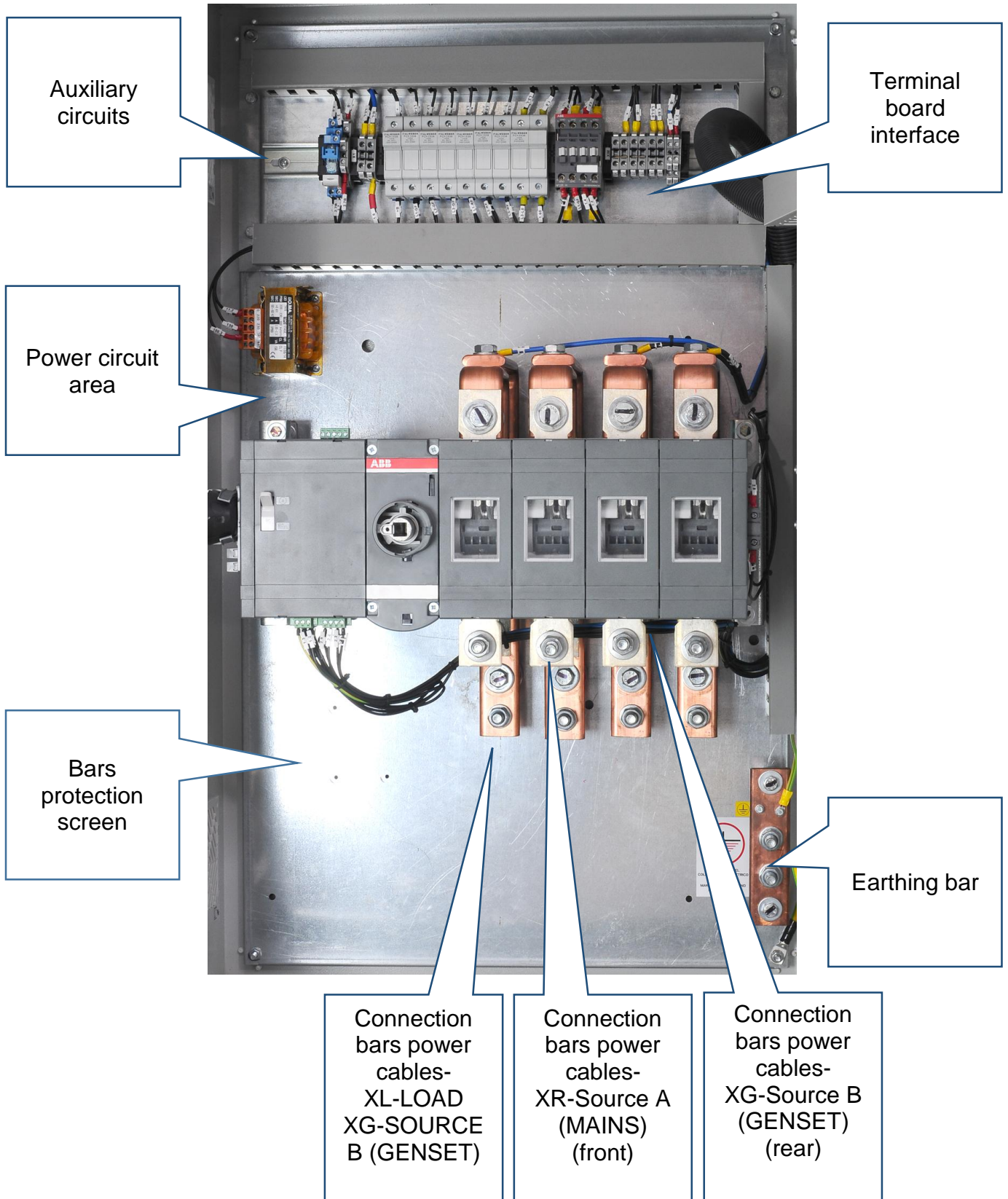

FLOOR STANDING CARPENTRY (1000÷2500A)

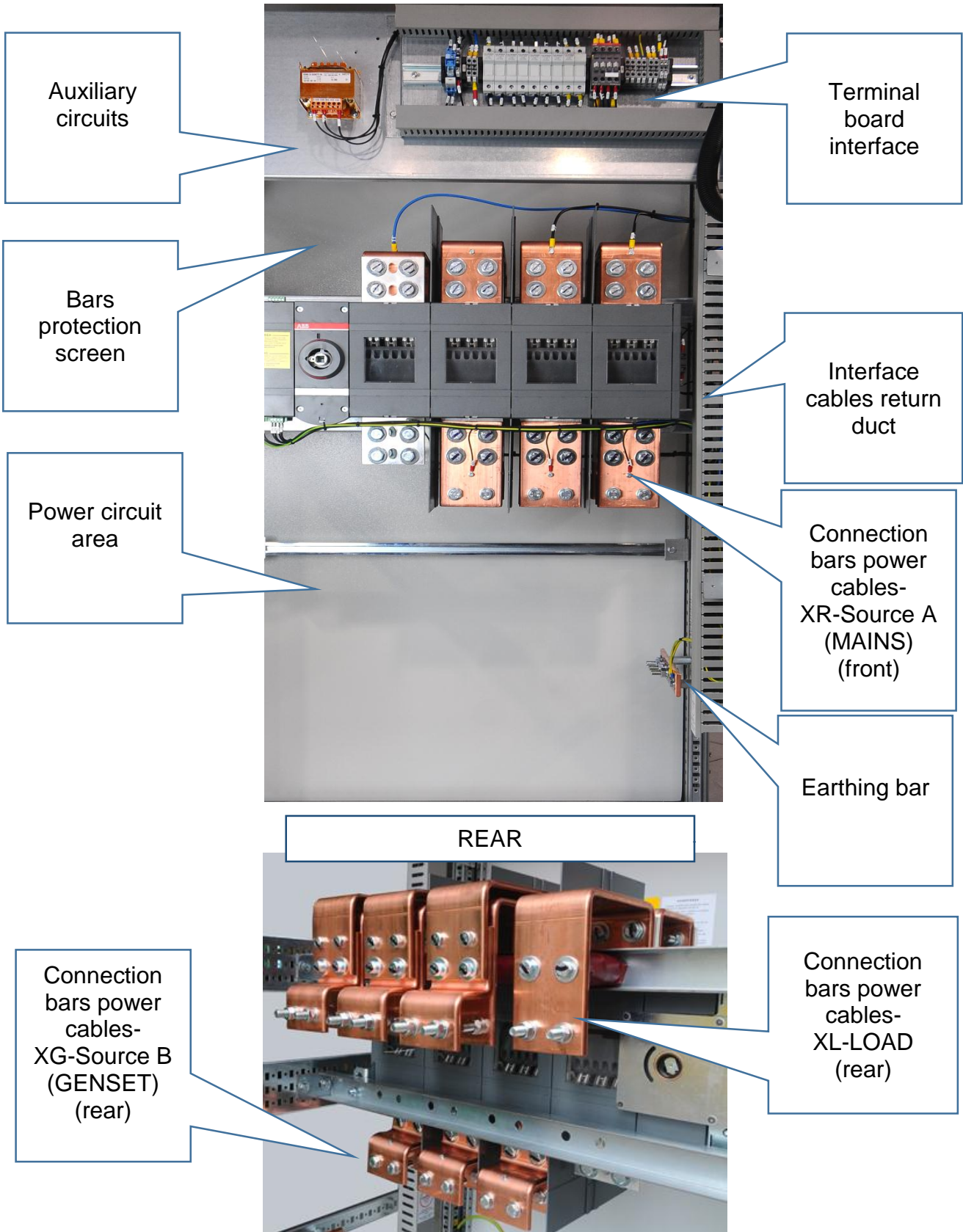

FLOOR STANDING CARPENTRY (3150÷4000A)

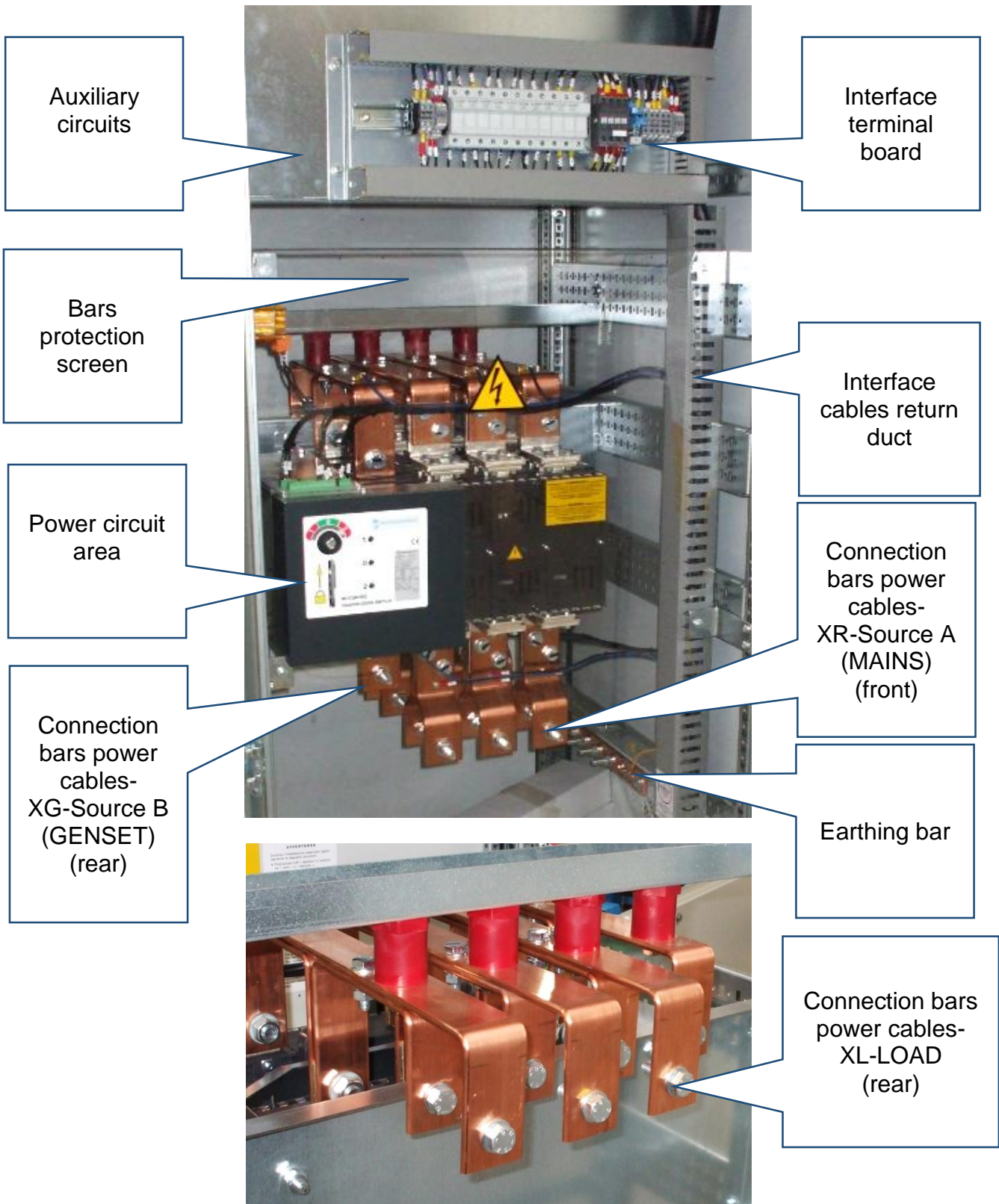

5.1 Connection interface terminal board (Switch and Auxiliaries)

Before supplying the control panel with voltage on the Source A (Mains), make sure of:

- The respect of the above indications related to the installing, the electrical diagram connection and sections suggested.
- The respect of all the instructions and precautions described in the attachment supplied in the documentation provided with respect to the operating voltage switch.
- Keep the ATS115 key pressed to move it on OFF.

WARNING: in order to avoid the cables whiplash and the switch damage in case of court circuit, it is necessary to fasten the power cables once connected to the switch.
Below there is a principle scheme showing how to interface the panel with the plant. With regard to the power connections, we can consider 2 types: with contactors (45÷125A), with motorized changeover switch (160÷2500A). The XM auxiliary command is the same for both types.

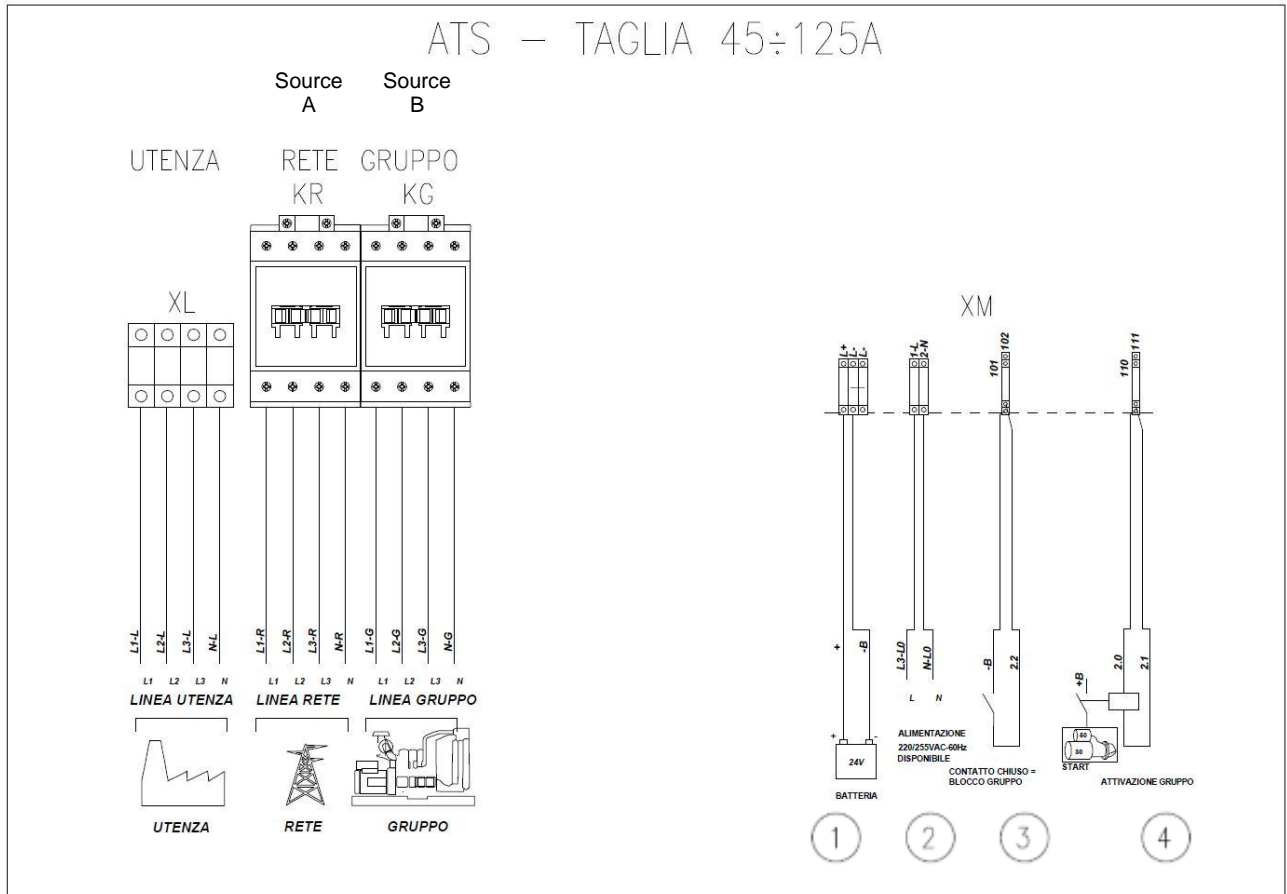

- Couple of ABB contactors -

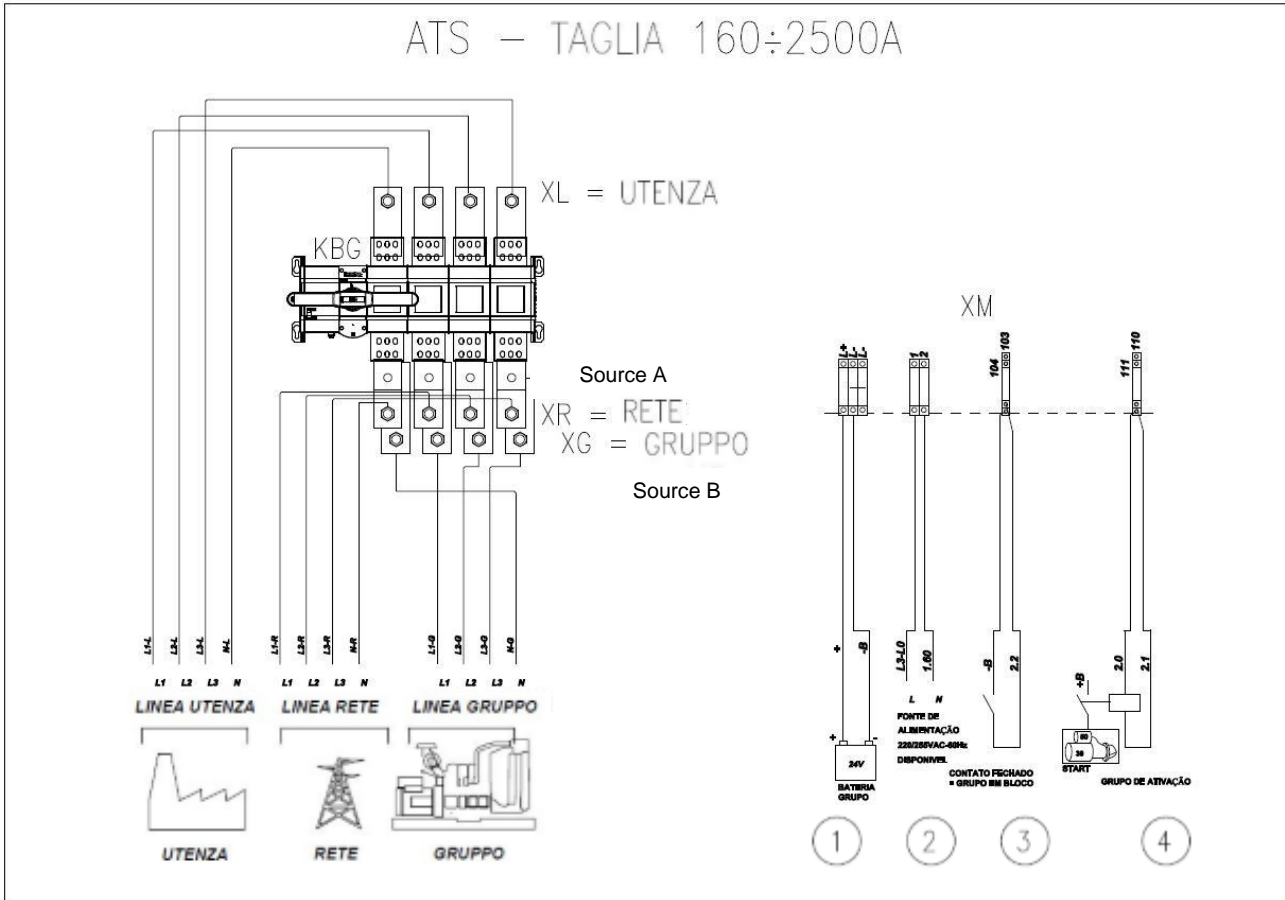

- ABB changeover switch -

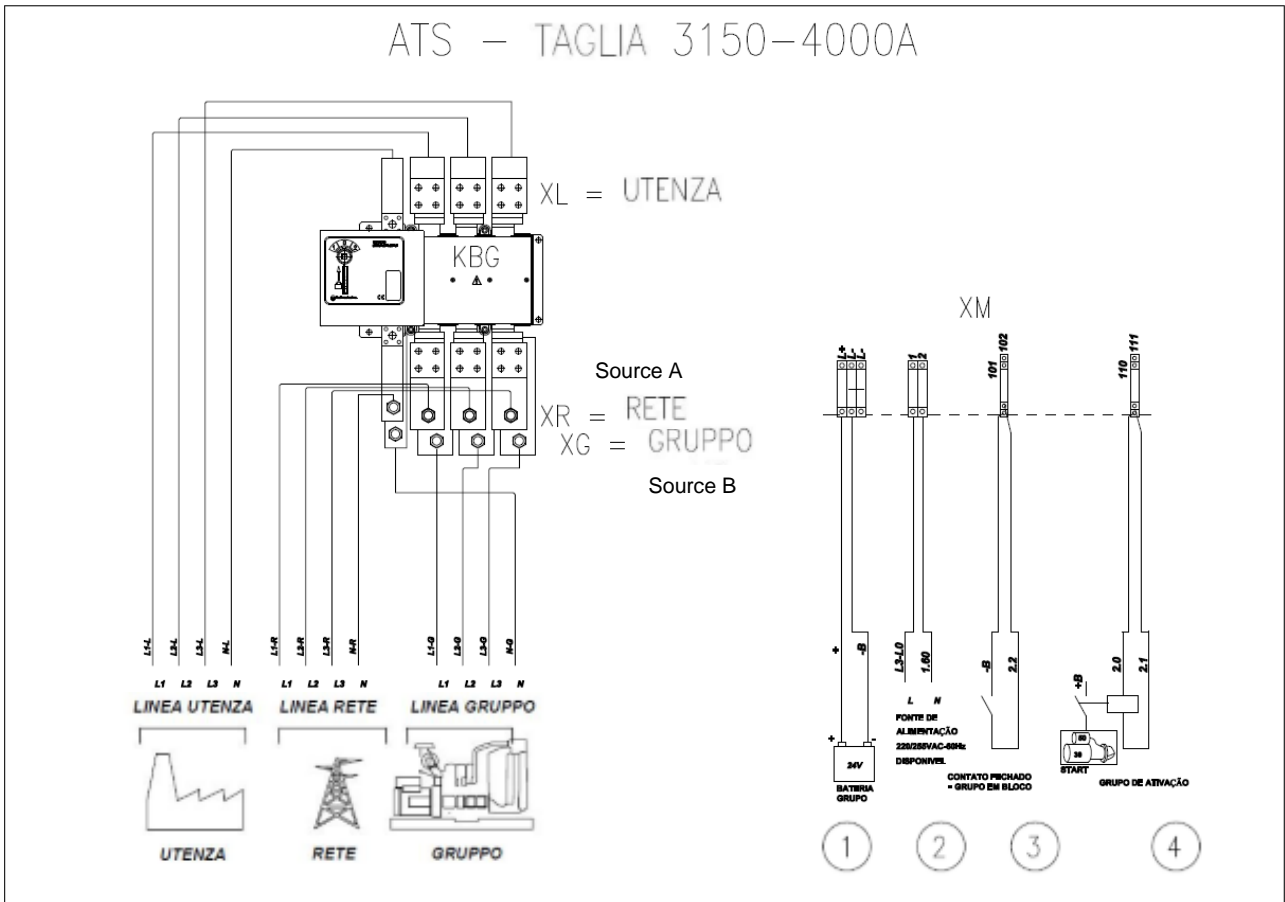

TECHNOELECTRIC motorized changeover switch

In particular, the auxiliary terminal board XM allows the connection with the system (the arrow represents the signal direction):

Panel ← → System

- 1) Supply 24Vdc (from the engine battery) ←
- 2) Supply single-phase available →
 - a. Voltage 220V – 60Hz = 220V – 60Hz
 - b. Voltage 380V – 60Hz = 220V – 60Hz
 - c. Voltage 440V – 60Hz = 255V – 60Hz
- 3) External stop contact (the logic switches on SOURCE A (MAINS)) ←
- 4) Possible release of SOURCE B (GENSET), removed by alarm device, on OFF or with SOURCE A (MAINS) live. →

6. Options available and possible configurations of the controller

6.1 Battery Charger SW 5A 12Vdc or 24Vdc (see also related datasheet)

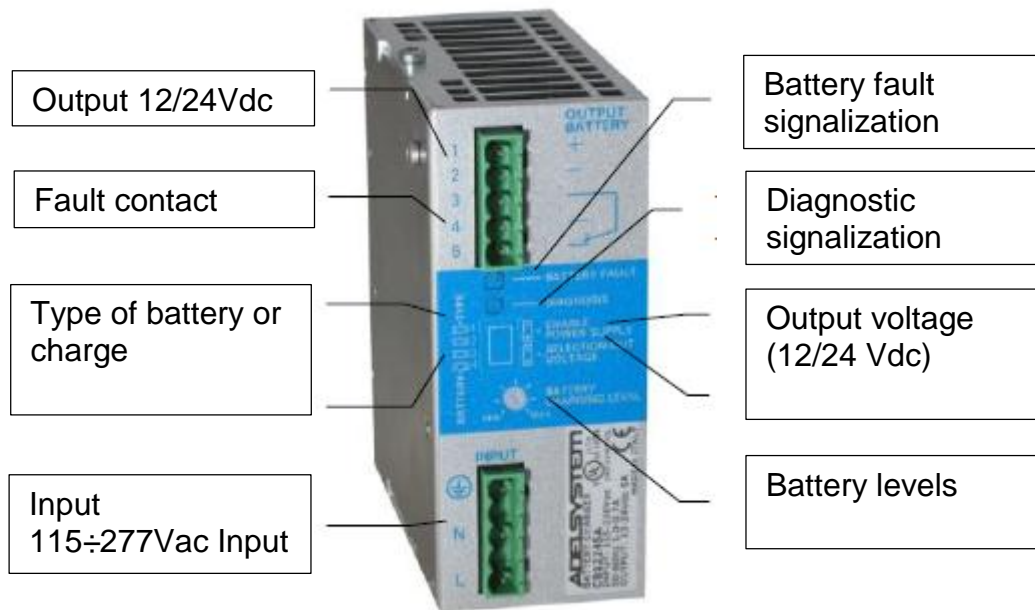

The battery charger is equipped with jumpers for the configuration according to the diagram indicated later.

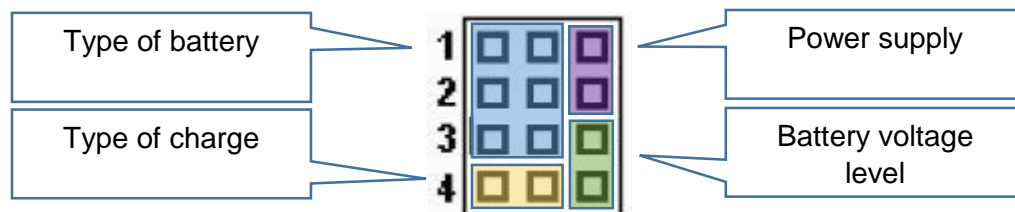

Configuration of the output voltage level

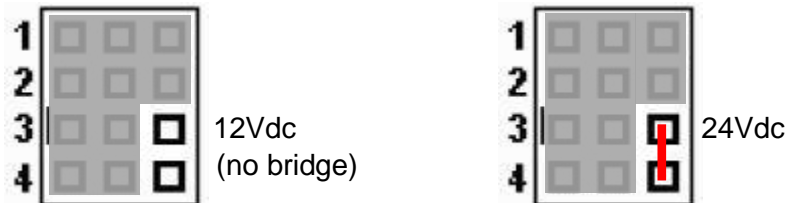

Configuration of the battery charger as supply	Configuration of the rapid charge	Configuration of the type of battery (see manual attached)
--	-----------------------------------	--

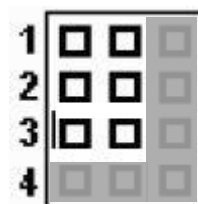
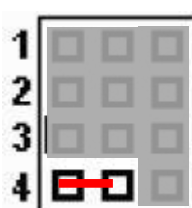
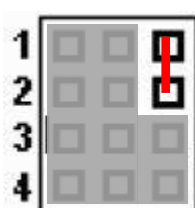

6.2 Management of two Gensets switching

Option kit diodes bridge D1

When the Sources A and B are 2 Gensets, both batteries positive power supply must be connected as follows:

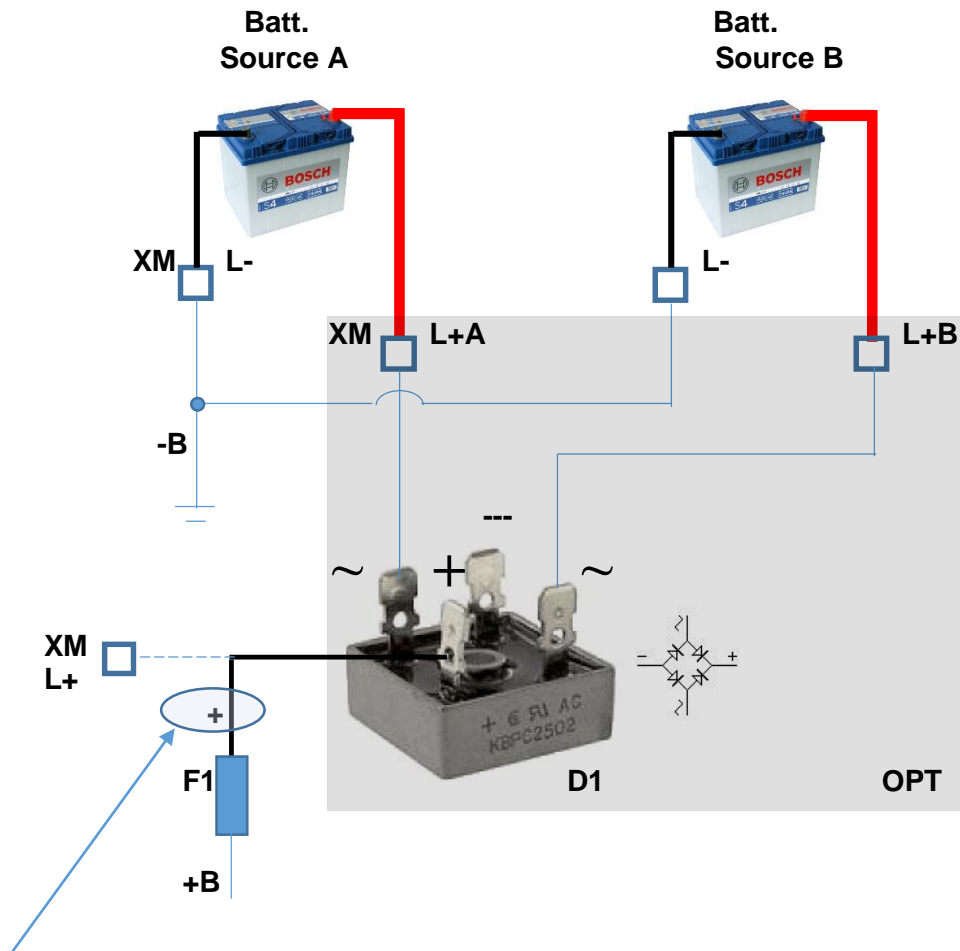

The wire +, currently connected to the terminal **XM-L+** by the fuse **F1**, must be disconnected from the terminal **L+** and connected to the + of the diodes bridge **D1** as shown in the figure.

Option kit relay KA

The approval for the activation of the Source A, as per the Source B, is made by the option **KA-RA** and the terminals **101-102-110-111** to add to the terminal board **XM**. Connect the option as indicated by the scheme.

	<p>WARNING: When connected to the relay KA, connect the wire 2.12A to the terminal 12/24 of RA according to the battery voltage.</p>
---	---

To manage the Source A as Genset you must configure the following parameters:

- P.0100 = 1
- P.0113 = 0.0
- P.0115 = 60.0
- P.0118 = 999.0
- P.0304 = 0-No
- P.2001 = 4004
- P.2002 = 1.0
- P.2003 = Source A stop
- P.3005 = 1001

6.3 Communication ports: RS232, ETHERNET, RS485 (only with ATS115Plus)

This controller is equipped with communication ports for the connection to PC, Modem, Networks, etc. (see also the ATS115Plus manual)

6.4 Inhibition

The controller is designed to acquire an input that inhibit the operation in case of lack of sources voltage. Accomplish the option wiring as reported in the diagram adding the terminals **105-106** to the terminal board **XM**.

Configure the parameter:

- P.0213 = 2501

6.5 CTs

The insertion of the CTs on the Load line allows to measure also the power supplied by the mains. For the CTs characteristics, see the indications on the ATS115 controller manual. The CT primary current has to be at least equal to the nominal current I_n of the plant.

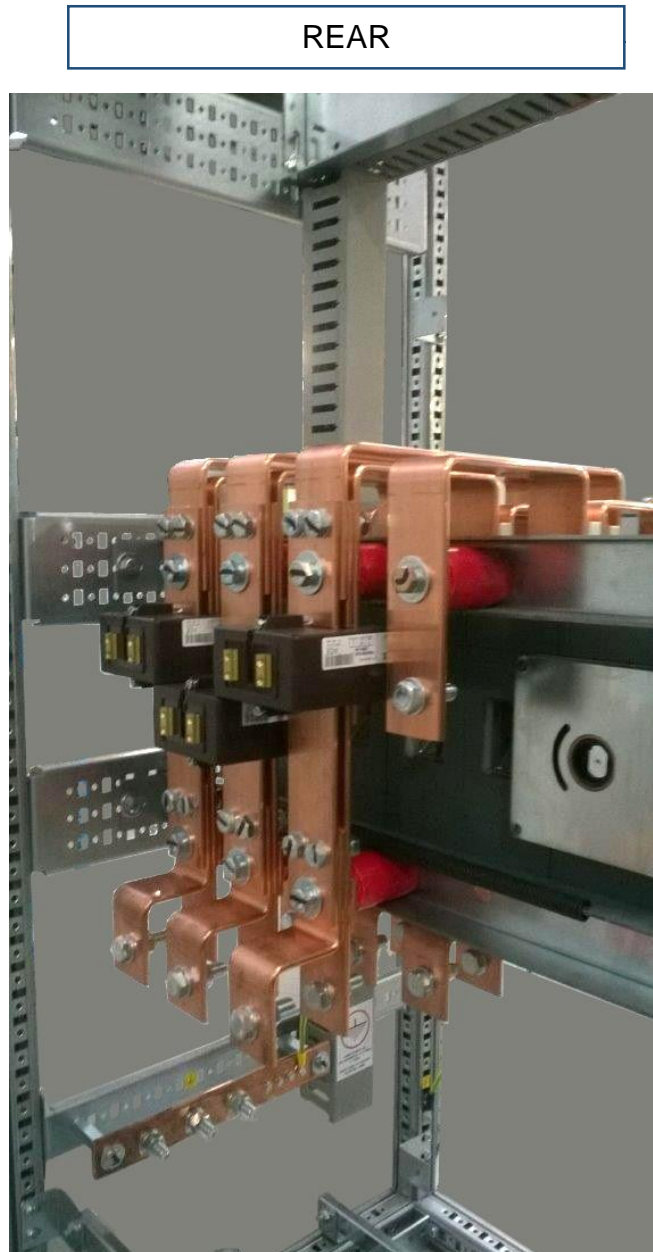

The CTs installation includes the board kit and possible fastening as shown in the figure below.



The parameters to configure on the controller are:

- P.0302 = CT primary current
- P.0303 = 2 – On Load
- P.0310 = 5 – CT secondary current





7. Check and maintenance (see also ATS115 manual)

	<p>Do not carry out maintenance, repair or modification procedures without having specific knowledge or receiving precise indications. All procedures must be carried out in compliance with the safety rules in force.</p>
	<p>WARNING THE ELECTRIC CONTROL PANEL IS SUPPLIED BY TWO DIFFERENT SOURCES, MAINS AND GENSET. THE ELECTRIC CONTROL PANEL WORKS EVEN WITH OPEN DOOR.</p>

Before carrying out any maintenance operation, ensure that both the Mains and Genset lines are clear of voltage. In case of panels equipped with protection bars, which must be removed for installation and maintenance, it's absolutely necessary to mount them again once the procedures are over.

Do not remove or force electrical components while the panel is on.

The opening key of the panel must be given exclusively to authorized personnel.

WARNING	OBJECT	PRECAUTION
 <p>DANGER</p>	<p>All the maintenance procedures must be carried out by skilled personnel only. All the control and maintenance activities must be carried out with genset stopped and after disconnecting the panel from all external sources of energy.</p> <p>PAY ATTENTION IN CASE OF EQUIPMENT WITH AUTOMATIC OR REMOTE STARTING SYSTEM:</p> <ul style="list-style-type: none"> - AUTOSTART; - MISSING MAINS SENSING DISPOSAL; - PROGRAMMABLE FUNCTION FOR AUTOMATIC TEST; - CONNECTION AND CONTROL FROM A PC VIA RS-485 SERIAL PORT, MODEM WITH CABLE OR GSM FIELD; <p>THESE ARE ALL FUNCTIONS THAT, IF THE GENSET IS NOT IN BLOCK MODE, CAN PERMIT IT TO GET STARTED EVEN DURING MAINTENANCE OPERATIONS, CAUSING DANGER TO THE TECHNICIAN WORKING ON THE UNIT.</p> <p>Disconnect the devices fed by the Mains, such as the engine preheating system or Mains sensing card. All operations requiring the removal of the protection barriers must be done in the above mentioned conditions ONLY. If the protections are removed, these must be reapplied before the next start-up.</p>	  

Remove voltage supply and turn off the unit in case of malfunction or fault.

It is prohibited to alter the electrical Panel's parts, position of the components and/or any mechanical and electrical components. Should the above direction be neglected, it may compromise the Panel's safety and it is immediate cause for the null and void of the warranty. Any change made to the panel will be the responsibility of the executor of the change; the executor then becomes the manufacturer.

8. Transport, storage and decommissioning

When storing the unit ensure that no other objects are put on top of the panel in order to avoid damages and/or risks of an accidental fall.

The transportation of the electric panel must be carried out so as to safeguard its integrity. Dimensions and weights are indicated on the Panel's identification label and in the documentation attached. (See chapter 10).

All floor standing carpentry over a certain weight is equipped by special rings to be lifted from the high...

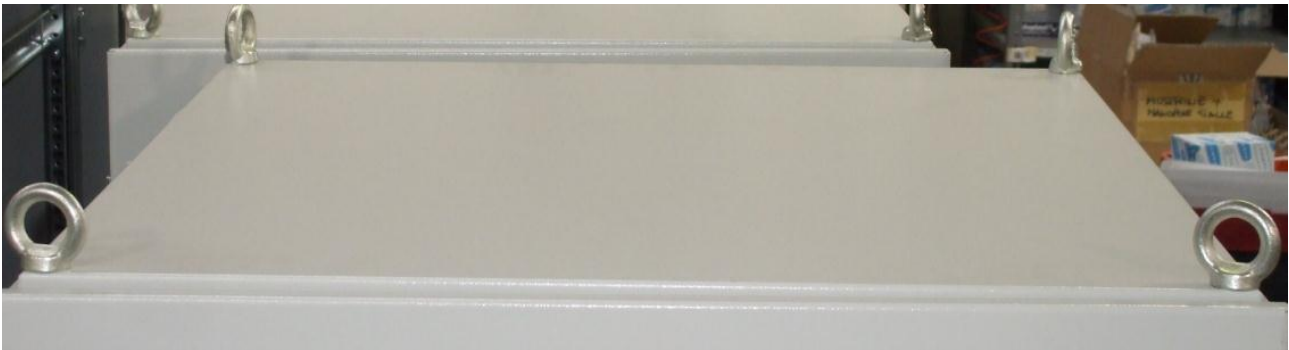

...and special base H:100 for the transportation from the bottom (traspallet).



On receipt of the Panel, check to see if there is any damage caused by transport and check to make sure that the details indicated on the identification label correspond to what was requested.

If the panel is not installed immediately but stored, it is necessary to take some precautionary measures in order to avoid damage to the external case and electrical components inside.

Store the packaged panel in a closed environment that covers and protects against weather conditions and animals. The humidity level must be between 30 and 75% with temperatures between -25°C and +55°C, and a maximum peak of 70°C for very short periods.

At the end of its life cycle or in case of demolition, the equipment has to be decommissioned according to the norms in force in the Country of use. It is also required that the identification labels and any other related document are appropriately destroyed.

9. Faults and possible causes (see also ATS115 manual)

Possible problems connected to the ATS LOGICA Panel are listed in the table below. These are general suppositions which are only needed to help explain the problem to the technicians who will then intervene to sort it out. Therefore, the info below has to be considered as general.

WARNING	POSSIBLE CAUSES
Alarm on ATS115: Genset stop	<ul style="list-style-type: none"> • The external contact cabled to the terminals XM-103 XM-104 is closed.
The selector does not close nor on Mains or on Genset.	<ul style="list-style-type: none"> • Source A (Mains) not live. Source B (Genset) stopped • Protection fuse burned. Replace the fuse. • The remote command of the switch is not allowed. Check the electric continuity of the consent cables and the status of the remote contact. • The contactor coil is broken (burned, interrupted)
With contactor/changeover switch inserted, a phase/neutral of the Source A (MAINS) or B (GENSET) is missing.	<ul style="list-style-type: none"> • Terminal board not correctly tightened. Tighten the terminals and check that the false contact has not burned the terminals. • A phase/neutral of the Source A (MAINS) or B (GENSET) is missing, because of distribution cable interruption. Check the distribution wires and the connection points.

In case of alarm, a flashing acoustic/optical signalling comes up. Then, the display automatically shows the page related to it with the description of the **active alarm**.

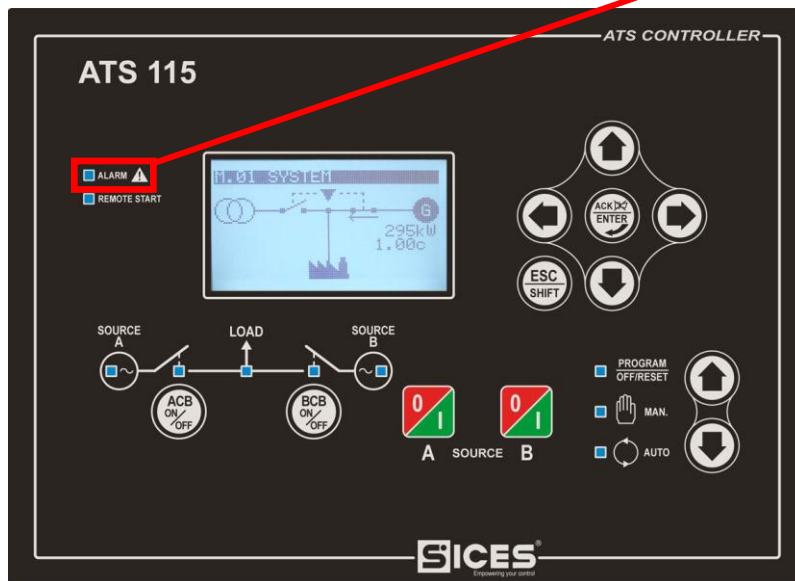

Press the acknowledgement button: once to take the acoustic alarm off; twice for the acknowledgement. With alarm acknowledged and still live the visual signalling keeps on flashing.

Remove the cause of the alarm.

If the alarm is of a Warning type, it is not necessary to reset the control card; if it is an Alarm, it is necessary to reset the control card setting OFF mode.

In OFF mode the display goes back to the last active page in the moment before the alarm and the visual signalling turns off.

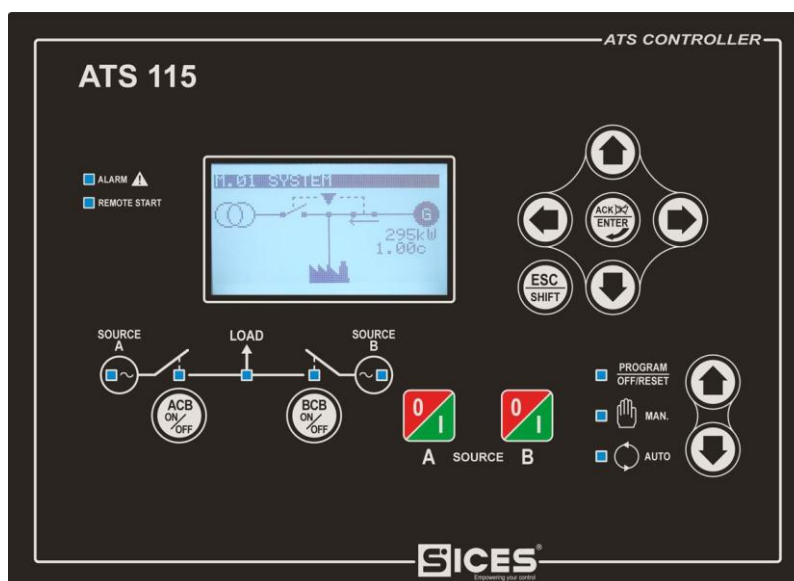

Afterwards, set the control card in AUTO position again.

10. How to ask for assistance

To shorten the intervention time of SICES Technical Assistance (SAT) please follow the below shown procedure, providing the required data thus allowing an easy problem solving:

Try to identify the origin of the fault by consulting the above table;

Contact SICES Technical Assistance SAT having the following information at your fingertips:

- 1) Control Panel data as shown in the plate affixed to the carpentry (**);
- 2) Purchasing document data (Invoice);
- 3) Name of the Company who made the purchase;
- 4) Description of the fault giving as much details as possible about the probable cause, wrong operation or improper use;

()**

It is very important to refer the Control Panel serial number. If you have already identified the component considered faulty it is useful to refer the written you find in it.

The warranty conditions are indicated in the document **GENERAL CONDITION OF SALE** and it is reminded that the warranty does not apply in the following cases:

- For any damages during the transport.
- For any defects/faults due to improper installation and/or start-up not responding to the safety rules in force.
- For any improper use different from the one given by the instructions provided.
- For any modifications or change performed without authorization.
- For damages due to atmospheric charges or Mains over-voltage of different origin.
- For use of non-original spare parts or with different characteristics from the original equipment.
- For any extraordinary events.

NOTE:

Do not wait until the components are worn out. Replacing a component means improving the efficiency of the control Panel itself and also avoiding more serious damages.

11. Our range: overall dimensions



A	H	L	D	Kg
45	600	400	200	21
70	600	400	200	21
100	600	400	200	25
125	600	400	200	25
160	1000	600	250	56
250	1000	600	250	56
400	1000	600	300	60
630	1000	600	400	90
800	1000	600	400	100
1000	1900	800	600	245
1250	1900	800	600	245
1600	1900	800	600	275
2000	1900	1000	800	335
2500	1900	1000	800	390
3150	1900	1000	1000	500
4000	1900	1000	1000	700



**This document is property of SICES s.r.l.. All rights reserved.
SICES s.r.l. reserves the right to modify this document without prior notice.
SICES has made any effort to ensure that the information herein provide are correct; in any case
SICES does not assume any liability for the use these information.
The disclosure by any means of this document to third parties is not allowed.**

**S.I.C.E.S. SRL
Società Italiana Costruzioni Elettriche Sumirago**

Via Molinello 8B
21040 - Jerago con Orago (VA) ITALY

T +39 0331 212941
F +39 0331 216102

www.sices.eu
sales@sices.eu

SICES BRASIL LTDA

Avenida Portugal, 1174
Condomínio Empresarial ONIX
06696-060 / ITAPEVI (SP)

T +55 11 4193 2008

www.sicesbrasil.com.br
comercial@sicesbrasil.com.br

